

SEZ-KD12NA INDOOR FAN PERFORMANCE AND CORRECTED AIR FLOW CHARTS

SEZ-KD12NA

(External static pressure 0.02[in.WG](5Pa)) 208/230V 60Hz

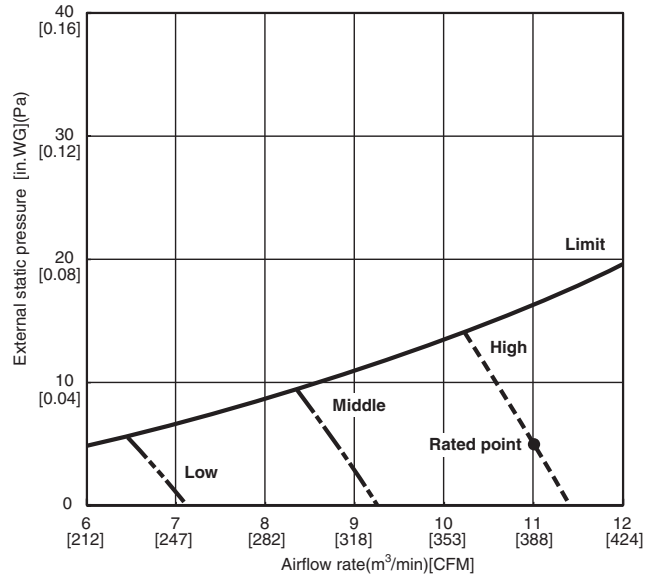

SEZ-KD12NA

(External static pressure 0.06[in.WG](15Pa)) 208/230V 60Hz

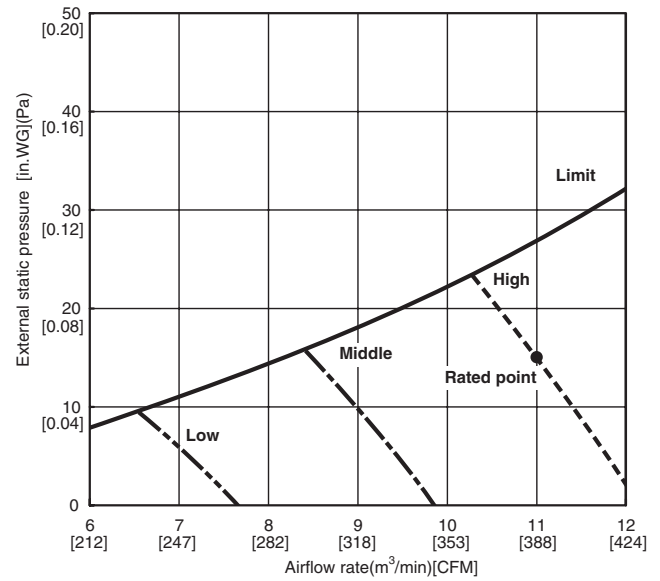

SEZ-KD12NA

(External static pressure 0.14[in.WG](35Pa)) 208/230V 60Hz

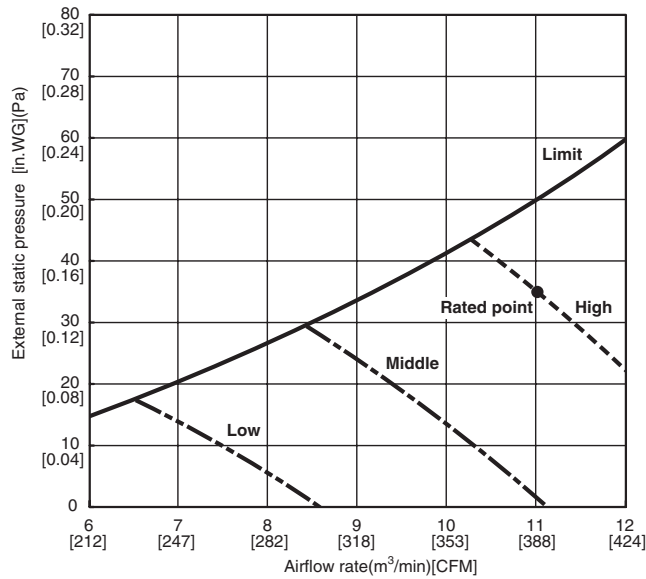

SEZ-KD12NA

(External static pressure 0.20[in.WG](50Pa)) 208/230V 60Hz

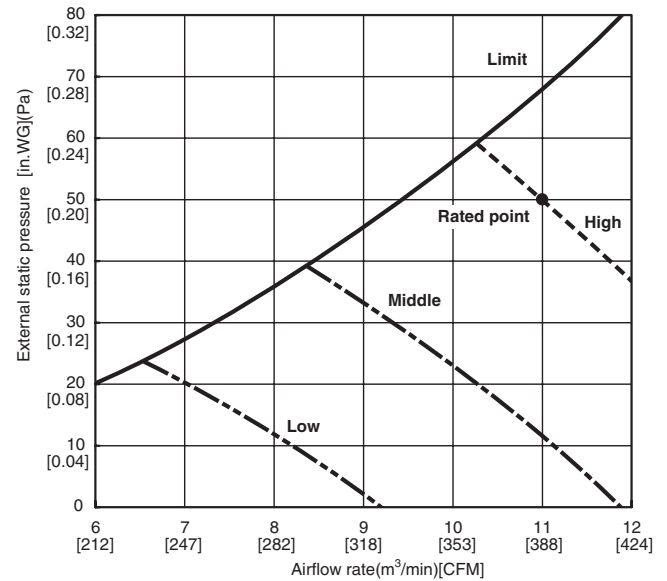

DIMENSIONS: SEZ-KD12NA

Unit : mm(in.)

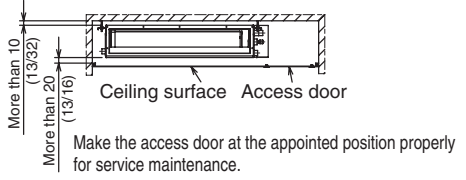
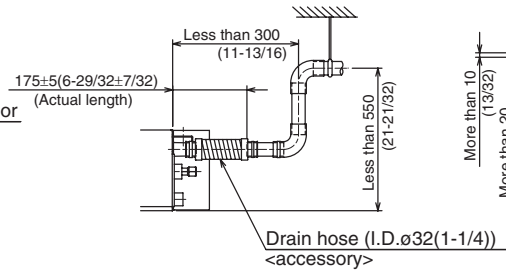
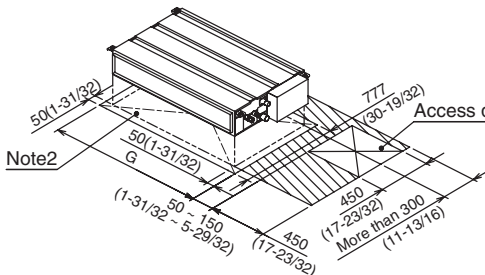
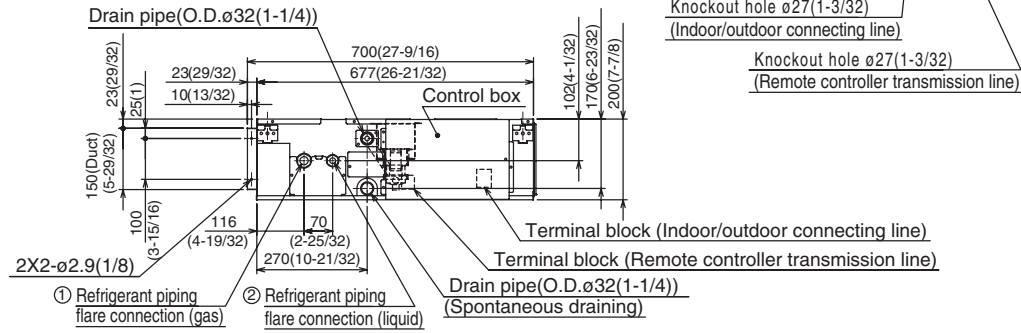
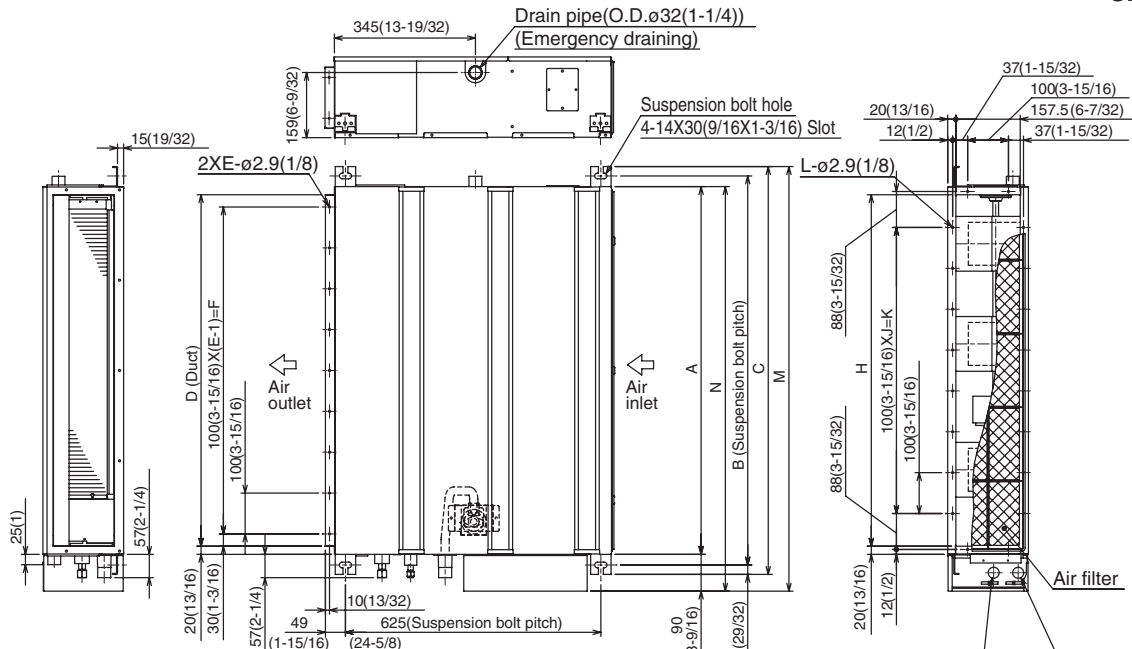

Required space for service and maintenance

Model	mm(in.)													① Gas pipe	② Liquid pipe
	A	B	C	D	E	F	G	H	J	K	L	M	N		
SEZ-KD09NA	700 (27-9/16)	752 (29-5/8)	798 (31-7/16)	660 (26)	7	600 (23-5/8)	800 (31-1/2)	660 (26)	5	500 (19-11/16)	16	839 (33-1/16)	790 (31-1/8)	ø9.52(3/8)	ø6.35(1/4)
SEZ-KD12NA	900 (35-7/16)	952 (37-1/2)	998 (39-5/16)	860 (33-7/8)	9	800 (31-1/2)	1000 (39-3/8)	860 (33-7/8)	7	700 (27-9/16)	20	1039 (40-29/32)	990 (39)		
SEZ-KD15NA	1100 (43-5/16)	1152 (45-3/8)	1198 (47-3/16)	1060 (41-3/4)	11	1000 (39-3/8)	1200 (47-1/4)	1060 (41-3/4)	9	900 (35-7/16)	24	1239 (48-25/32)	1190 (46-7/8)		
SEZ-KD18NA															

- Note1. Use M10 screw for the suspension bolt (field supply).
 Note2. Keep the service space for the maintenance at the bottom.
 Note3. This chart indicates for SEZ-KD15NA model, which has 3 fans.
 SEZ-KD09, 12NA models have 2 fans.
 SEZ-KD18NA models have 4 fans.
 Note4. In case an inlet duct is used, remove the air filter (supply with the unit), then install the filter (field supply) at suction side.

DIMENSIONS: SUZ-KA12NA

Unit: inch

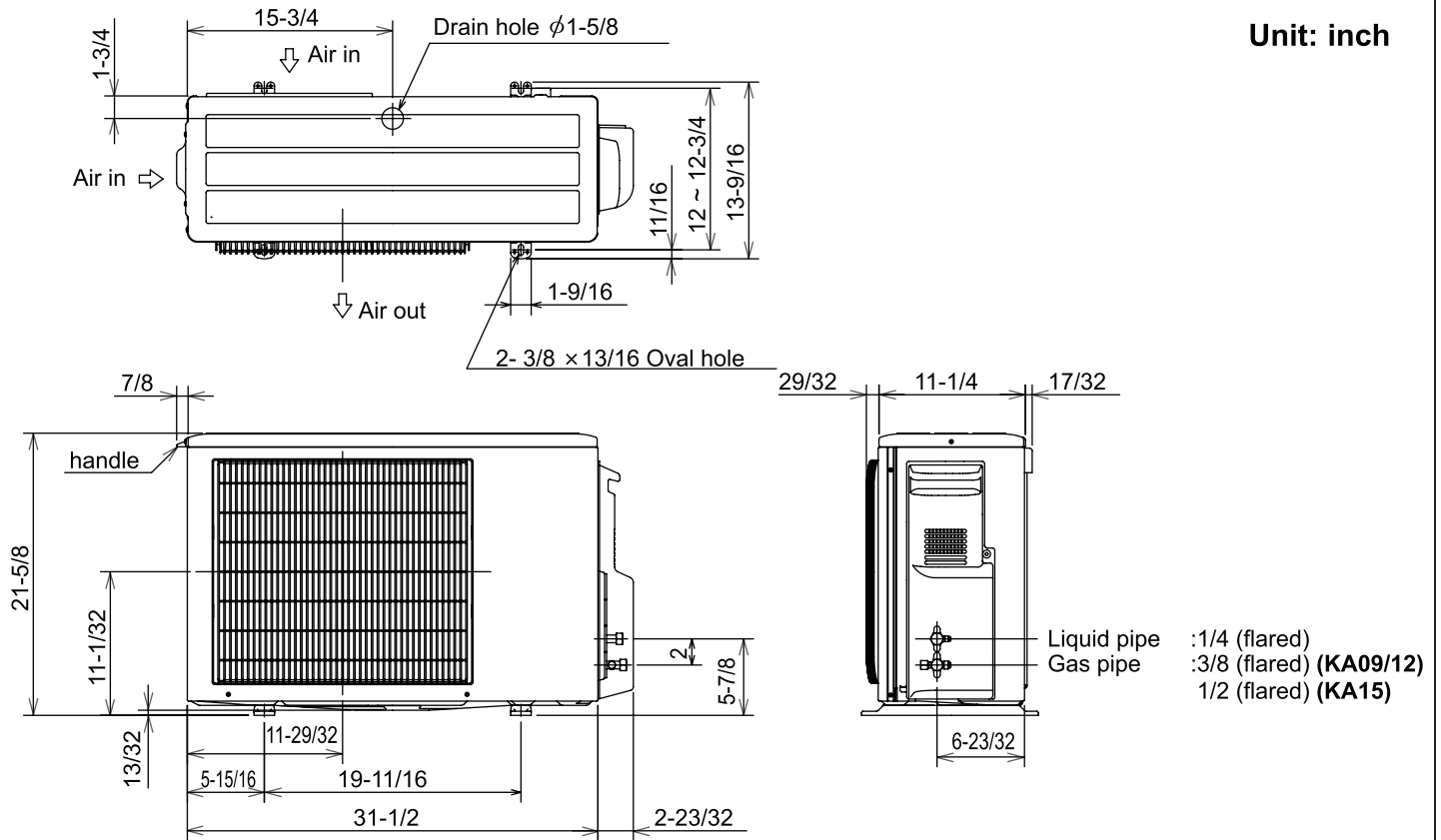

REQUIRED SPACE

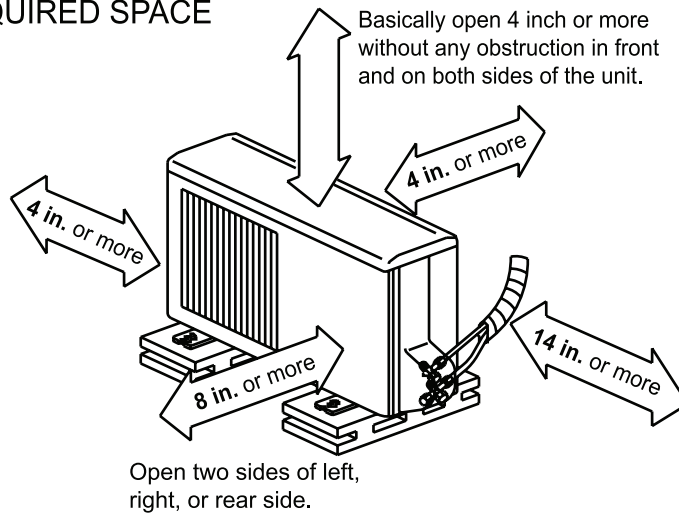

HVAC Advanced Products Division
 3400 Lawrenceville Suwanee Rd
 Suwanee, GA 30024
 Tele: 678-376-2900 • Fax: 800-889-9904
 Toll Free: 800-433-4822 (#3)
 www.mehvac.com
Specifications are subject to change without notice.