

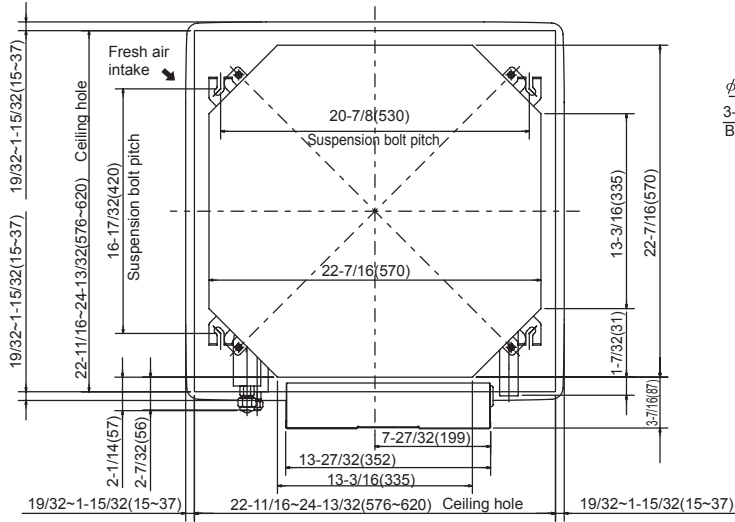

# DIMENSIONS: SLZ-KA12NA

Unit : inch (mm)



### Detail drawing of fresh air intake

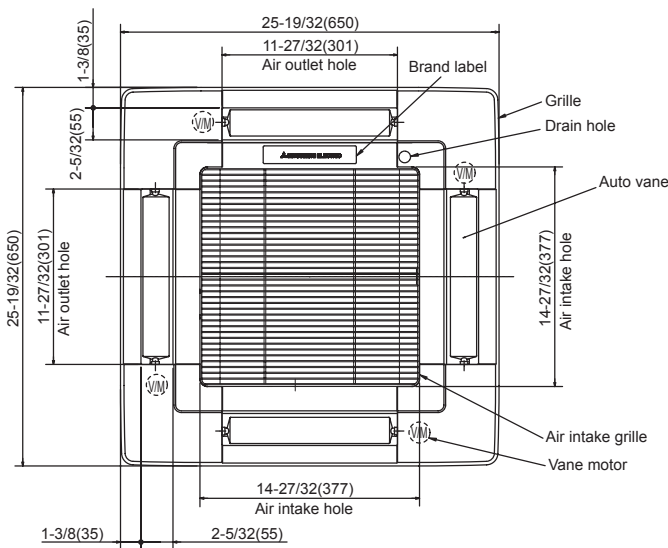
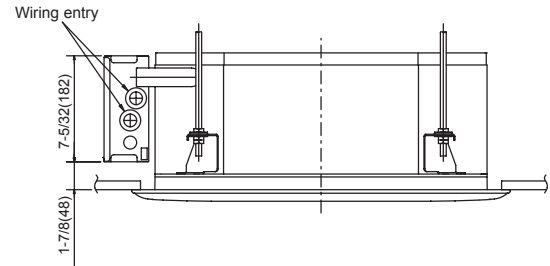
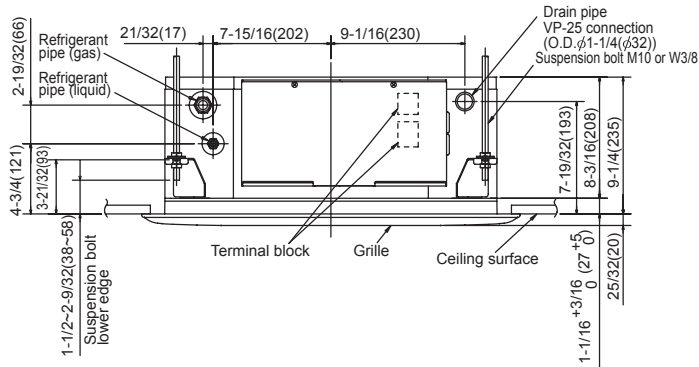
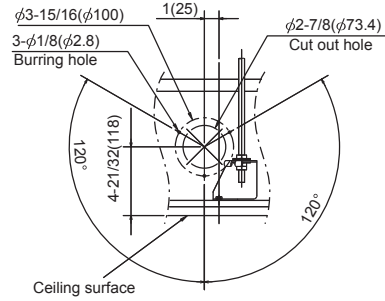

Models	Refrigerent pipe (liquid)	Refrigerent pipe (gas)
SLZ-KA09NA	1/4 inch (φ 6.35mm) flared connection	3/8 inch (φ 9.52mm) flared connection
SLZ-KA12NA	1/4 inch (φ 6.35mm) flared connection	3/8 inch (φ 9.52mm) flared connection
SLZ-KA15NA	1/4 inch (φ 6.35mm) flared connection	1/2 inch (φ 12.7mm) flared connection

# DIMENSIONS: SUZ-KA12NA

**Unit: inch**

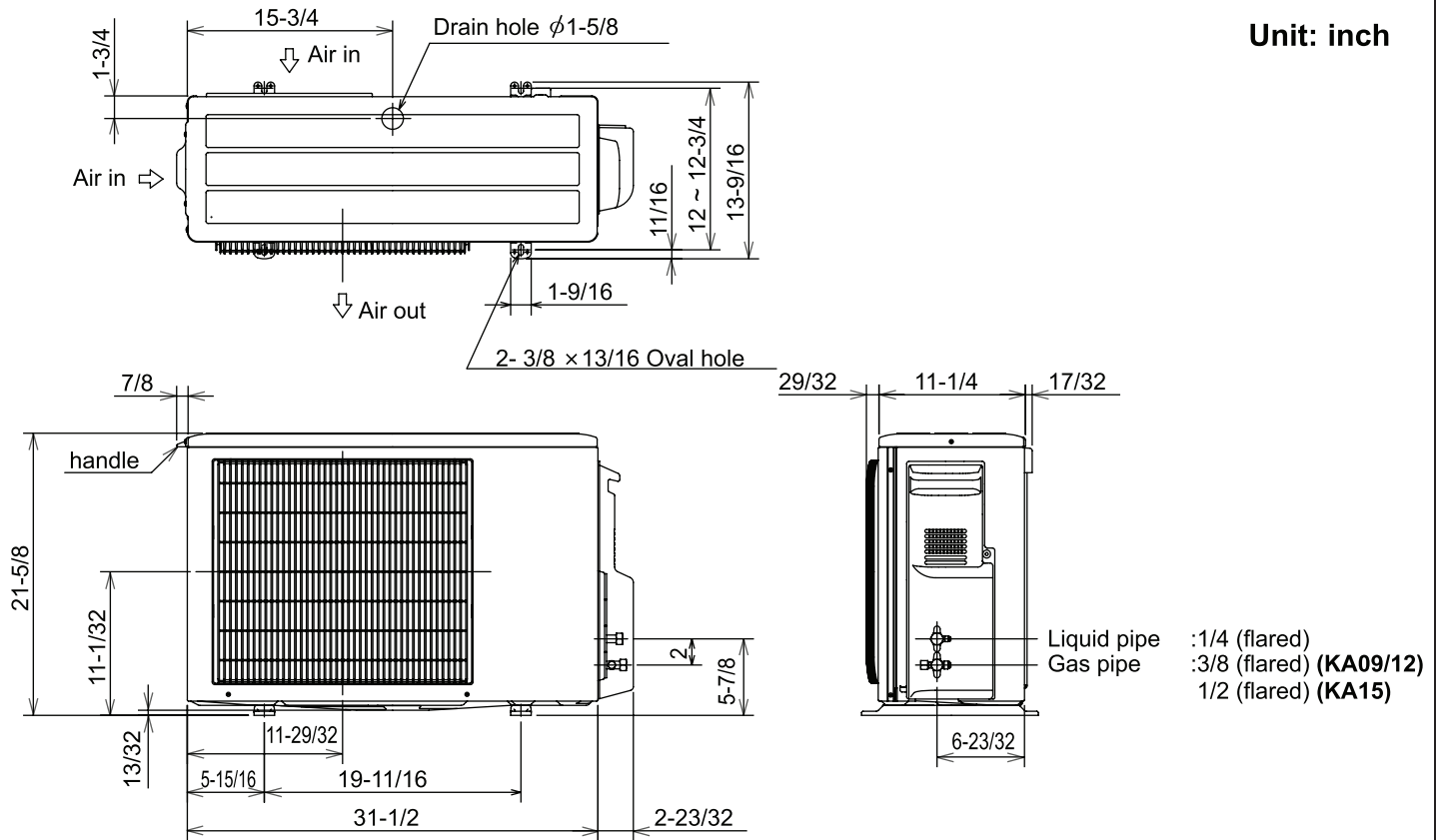

## REQUIRED SPACE

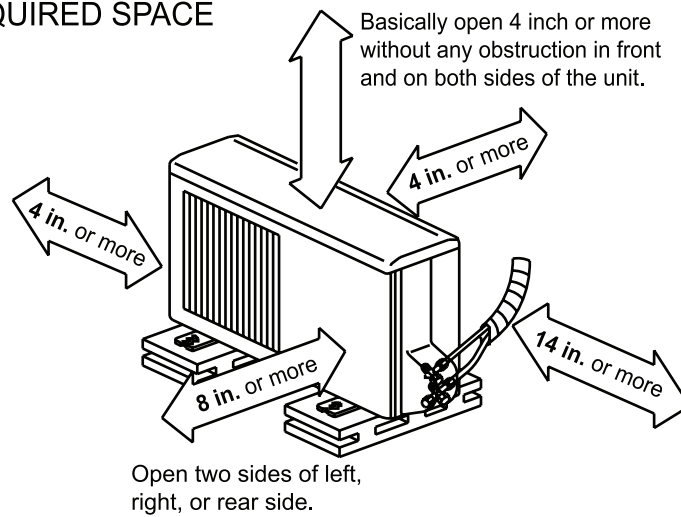

**Intertek**

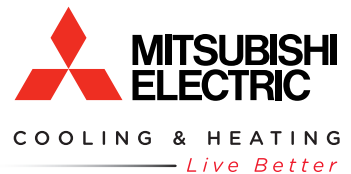

3400 Lawrenceville Suwanee Rd  
 Suwanee, GA 30024  
 Tele: 678-376-2900 • Fax: 800-889-9904  
 Toll Free: 800-433-4822 (#3)  
 www.mehvac.com  
**Specifications are subject to change without notice.**